

MD

Highest precision
metal detection



Competence in dynamic weighing.

A Wipotec Brand

OS
CHECKWEIGHERS

HACCP* compliant 100% in-line inspection

Safety and reliability are elementary facts in industrial manufacturing. Particularly in the sectors of food and pharmaceuticals the top priority is the safety of the consumer when using the product. To control any possible weight variations or to maintain the smallest filling quantity limits you should use our fast and high-precision in-line checkweighers.

With our metal detectors you can check your products reliably for any possible metal contamination. The smallest ferrous, stainless steel or non-ferrous particles, which may occur as abraded particles from parts which are rubbing together or turning, are safely detected and ejected from the product flow by a sorting device.



* Hazard Analysis Critical Control Point

Two components which complement each other perfectly:

Detector coil

- ➔ An electro-magnetic field is generated by means of copper wire windings with current flowing through them. Metal contamination in the product flow changes the high-frequency field inside the detector coil.

Evaluation electronics

- ➔ The smallest field changes (energy displacements) are detected by the intelligent evaluation electronics and converted to a switching pulse. This is then used, depending upon the application, for specific product rejection.



Continuous on-screen signal profile (here with metal detection)

Functioning method (simplified)

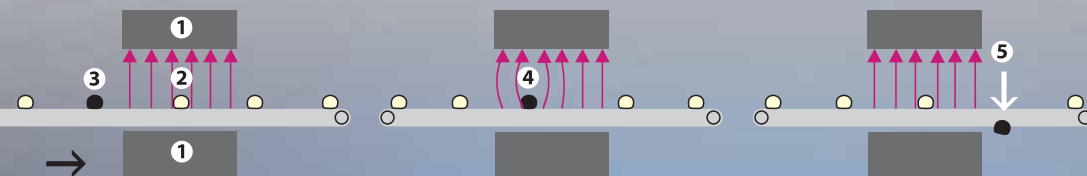

- 1 Metal detector
- 2 Electro-magnetic field
- 3 Metal-contaminated product
- 4 Field change in the event of contamination
- 5 Ejection of metal-contaminated product



Solutions for singles...

You want to have independence and you demand maximum flexibility in your selection of components. The amount of space is not important, on the other hand however product safety and liability play a very important role. This makes our stand-alone solutions perfect for you.

We offer individual subframes as well as independent drive systems. Installation options within your production process and the almost endless range of passage sizes. To match your existing line concept a selection of different types of conveyor and roller diameters are available.

Operation of the metal detector is carried out with menu guidance and intuitively via the large touch display. Application-specific ejection systems round off our wide variety of stand-alone systems.



Metal detector as a stand-alone version

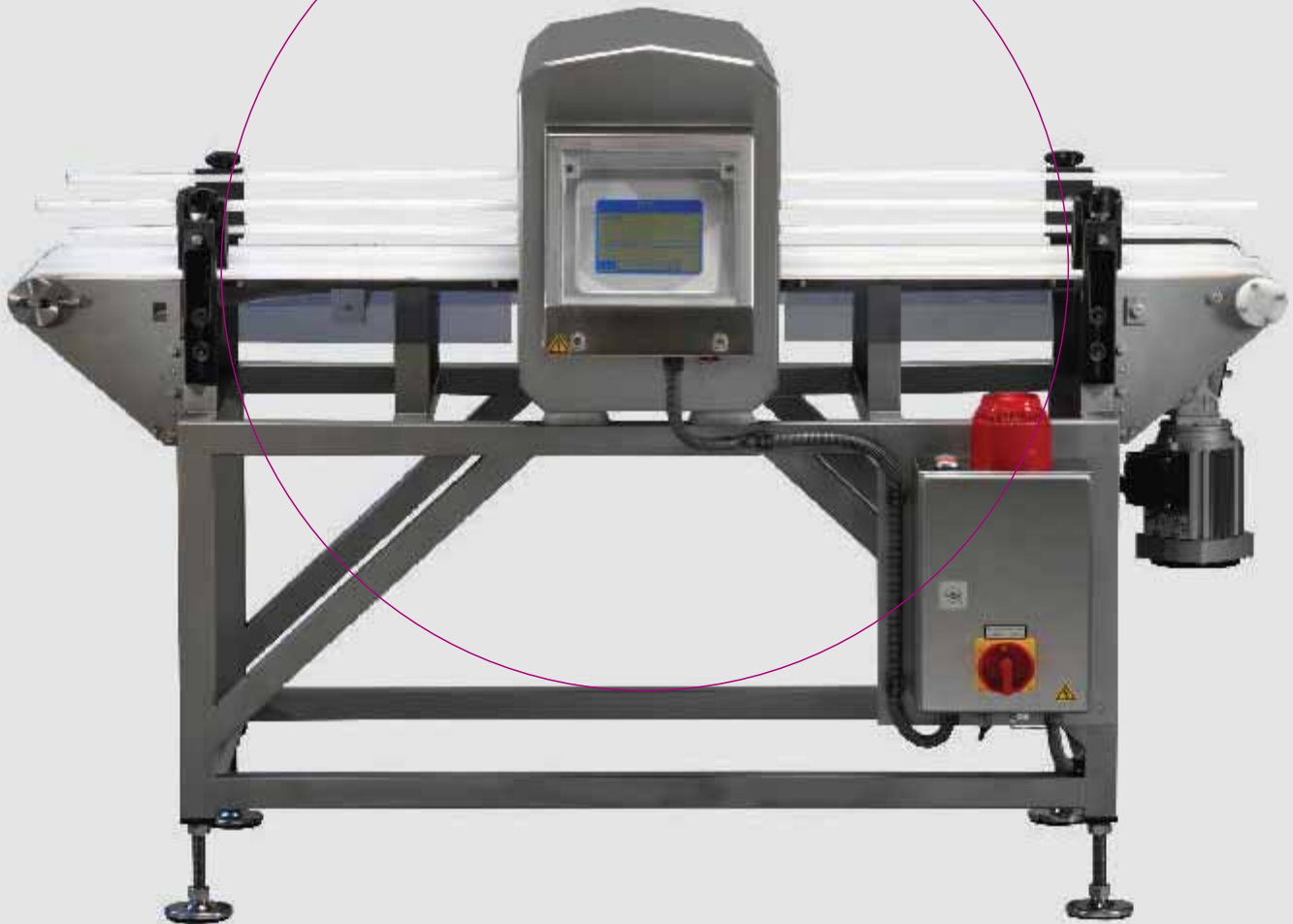

...sensitive vigilance...

OCS metal detectors: Application-specific and the simplest integration into your production line.

PHARMATRON: For pharmaceutical products such as tablets and dragées.

P-TRON: For liquid products and the meat and sausage processing industry.



...integrated system combinations

Our complete solutions offer high-performance technology in the most confined space. Due to the integration of the two components (dynamic checkweigher and metal detector), the HC-MD*i* has advantages in quality, synchronicity and use of space:

Space-saving combination of metal detector and checkweigher on one subframe

Simple, menu-guided operation of the whole system via the central weighing unit controller (all data is changed from one location for both devices).

With the help of a mature and wide range of ejection devices such as for example pushers, blowing nozzles etc., open or packed products are sorted according to incorrect weight or metallic contamination.

Transport belts and Weigh Cells can be obtained in stainless steel as an option.

Metal detector + Checkweigher = Application-oriented 2 in 1 solution



Combined operation and status display via the HC-MD*i* checkweigher.

HC-MD*i* Twin Inspection:
Checkweigher and metal detector integrated into one subframe to save space.

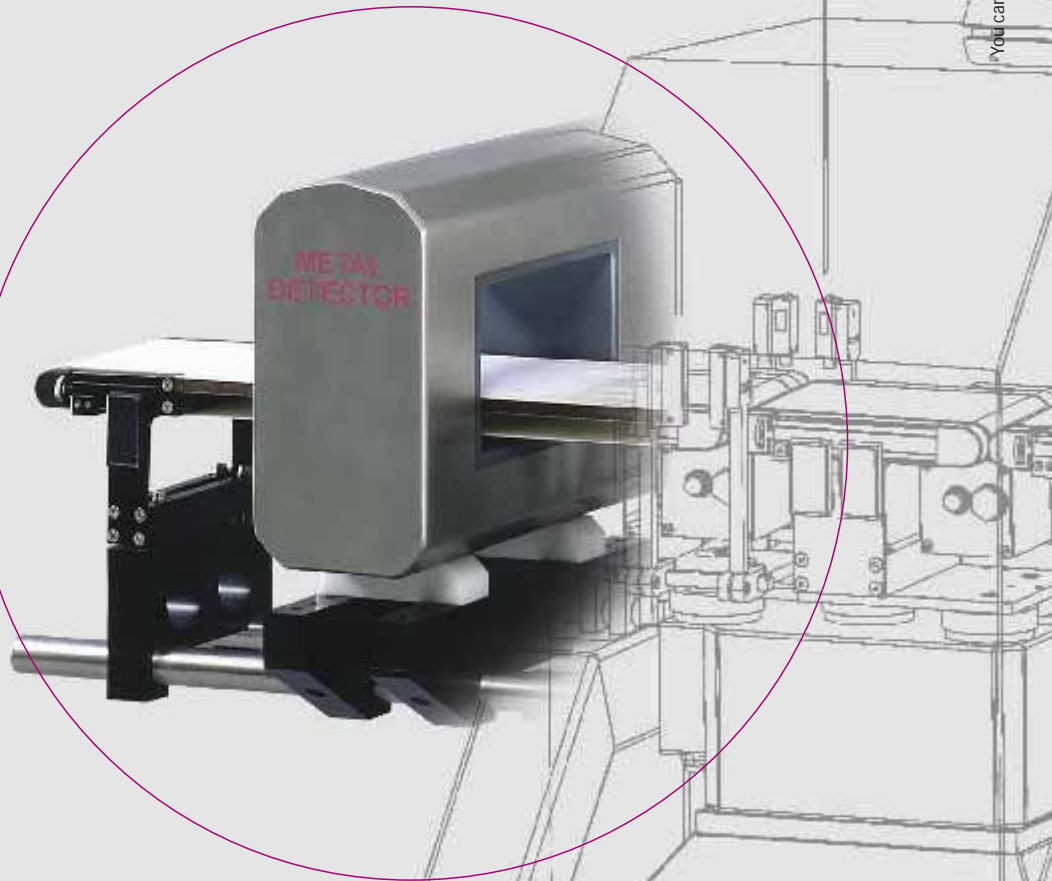

You can find more information in our checkweigher brochures

Your guarantee for highest product quality and cost control

EC-SMB

EC-M

HC-MD*i*



The Technology at a Glance

Safety on the whole line

- ➔
- Simple product teach-in (autolearning)
- High functional safety with permanent self-monitoring (autotesting)
- Detector test function, choice of manual or automatic
- Dynamic auto-tracking (product tracking)
- Touch screen control panel
- Complete documentation (ISO 9000/ protocol conforming with HACCP)
- Power failure-proof memory for product and rejection parameters
- Multifunctional filter system

The advantages of operating by means of the graphical touch screen

- ➔
- Clear and neat menu structure
- Graphic, intuitive menu guidance
- Direct control of all important functions with a light touch
- All control levels are reached rapidly and easily
- Display to show measurement signal and metal tripping thresholds
- Signal resolution: Display area for metal signal and metal triggering thresholds can be magnified and reduced
- Optical display for metal alarm



Options

- ➔
- Optical and acoustic signal devices
- Certified test bodies
- Report printer (interfaces: RS232, RS485)
- Remote control, network-capable
- Remote maintenance
- Various sorting devices
- Additional mains filter
- Isolated I/O-signals
- Stainless steel design
- Multi-frequency design

Special versions

- ➔
- Higher level of protection (explosion-proof protection)
- High temperature designs
- Evaluation electronics separate from search head in separate housing
- ALUTRON version (interference signals from metallized or aluminized foils are suppressed)
- Special voltages
- Special paints

Technical data

Sensor sensitivity (Fe spheres in mm)	V2A (stainless steel) = Fe spheres x 1 to 2 (depending upon the respective grade of alloy)
The smaller the coil opening, the higher the sensitivity	Non-ferrous metal = Fe spheres x 1.2 to 1.8 (depending on type of metal)
Max. conveying speed	Range 1: 0.05 to 6.0 m/sec (up to 30 m/sec as option)
Rejection time	Adjustable from 0.1 to 10s.
Transport belts	Various systems (application-specific belt width and belt length)
Type of protection	IP65
Relative air humidity	Up to 100%
Temperature	-10 to +50°C

Dimensions

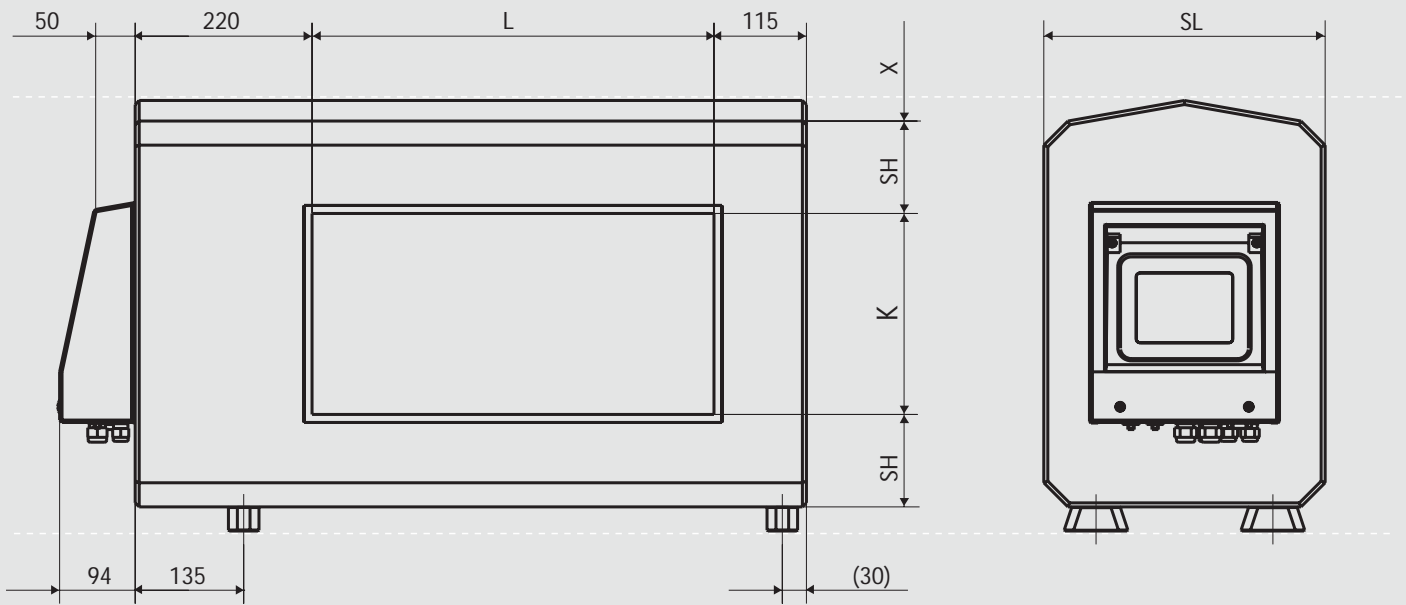

L (passage width) Selectable from 150 - 1,000 mm in steps of 50 mm.

K (passage height)	SL (coil length)	SH (coil height)	X (dimension)
100-125-150	260	115	18
175-200	300	115	22
225-250	350	115	26
275-300	400	115	27
325-350	450	115	31
375-400	500	115	36
425-450	550	115	40
475-500	600	115	44
550-600	650	115	49

All figures in mm. These are only guide values without application-specific attachments (e.g. sorting device).



Close to you with our worldwide service and sales network

A Wipotec Brand

