

HC-Letterscale VLS-630

For highspeed weighing in mail processing machines – technical datasheet

➔ Mail specification

Length (mm)	min. max.	125 250 (290*)
Height (mm)	min. max.	85 180
Thickness (mm)	min. max.	0,15 8
Mass (g)	min. max.	5 120
Speed (m/s)	min. max.	3,3 4
Accuracy (g)	+/-	+/- 1g

*) The max. length of 290 mm is only applicable to the speed of 3.3 m/s. At speed > 3.3 m/s, the accuracy of +/- 1g will not be guaranteed for letters > 250 mm

➔ Throughputs (for double lane systems*)

For the speed range of **3.3 to 4 m/s**, the following throughputs can be achieved (with full accuracy)

Min. Throughput **15.000-17.500 pph x 2**
For 250 (290*) mm long letters

Max. Throughput **22.000-25.000 pph x 2**
For 125 mm long letters

Aver. Throughput **16.750-19.250 pph x 2**
For 210 mm long letters

Nominal Sorter Gap **175-190 mm**
Depending on final scale length

Min. required Sorter Gap **145-165 mm** (for full accuracy)
For shortest letters, depending on mail sorter speed

Min. required Sorter Gap **120-135 mm** (for lower accuracy)
For shortest letters, depending on mail sorter speed

*) also available as single lane system

➔ Weigh Cell

EC-3000-FS-AVC series
Resolution ≥ 0.02 g
IP 44
Interface CAN
Active Vibration Compensation

➔ Certification

MID: DE-08-MI006-PTB 028

n_{max} 240
 e_{min} 0.5 g
 V_{max} 4 m/s
Temperature range 0-40°C

HC-Letterscale VLS-630

OCS Checkweighers GmbH
Adam-Hoffmann-Str. 26
67657 Kaiserslautern, Germany
mailog@ocs-cw.com
www.ocs-cw.com



CHECKWEIGHERS

A Wipotec Brand

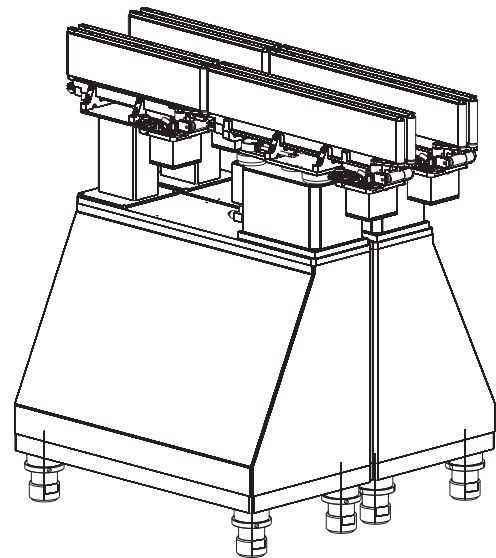
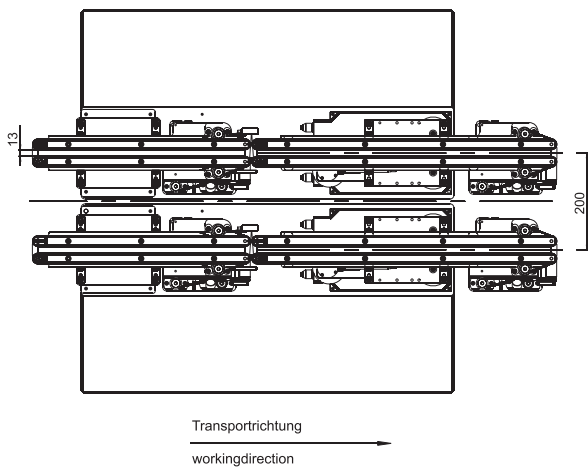
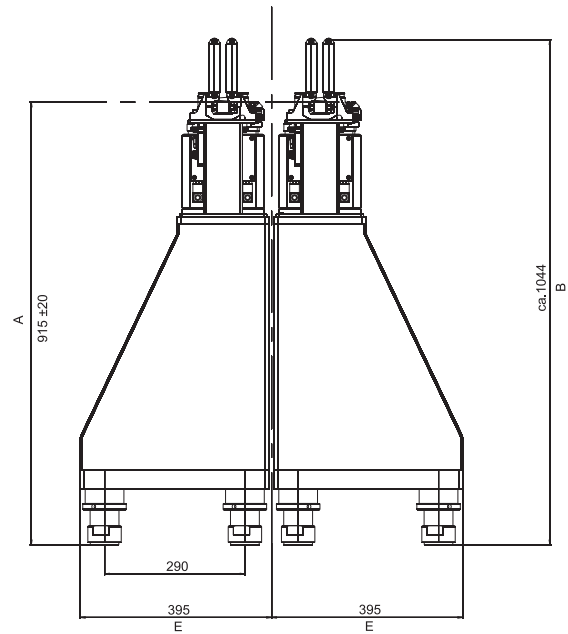
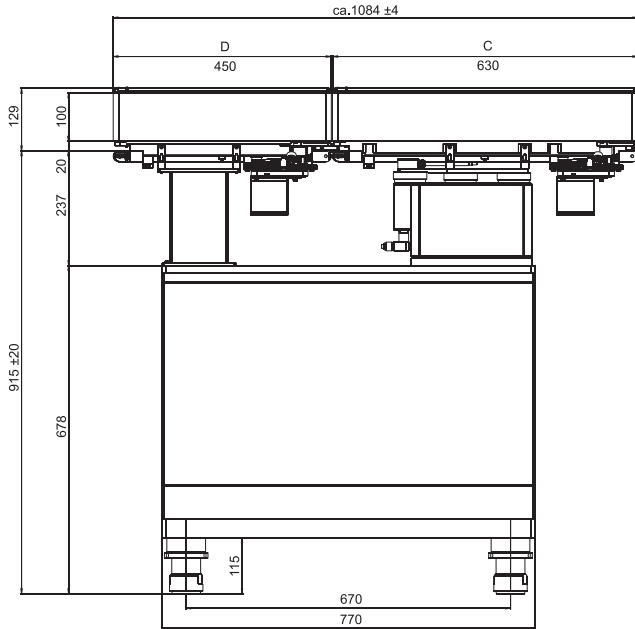

➔ Dimensions

Valid for HC-Letterscale VLS-630

A = Working height	915 ± 20
B = Total height	approx. 1044
C = Weighing belt length	630
D = Infeed length	450
E = Total depth	395 per lane

All measurements in mm.

These measurements are guideline values for a standard machine without application-specific and weighing-specific attachment parts.